

pcb - Depaneling Machine

NTE-200 L

Data sheet

With the panel separator **NTE-200 L**, pre-scored PCB panels can be separated gently and without bending stress for the circuit board and components. The cutting process takes place evenly and in parallel over the entire length. The tool opening can be continuously adjusted using a knurled screw. The drive is done by hand.

Technical specifications:

Drive:	By hand lever.
Separation.- length:	up to 200 mm.
Tool opening:-	adjustable up to 1.5 mm with knurled screw.
Weight:	approx. 45 kg.

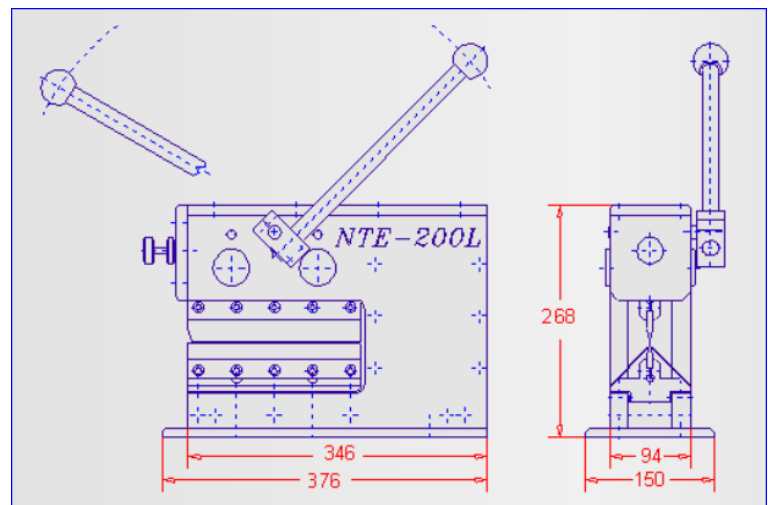

Scope of delivery

Table-top device including 2 sets of cutting tools, optionally Form **A** to **E**.

Tools forms.

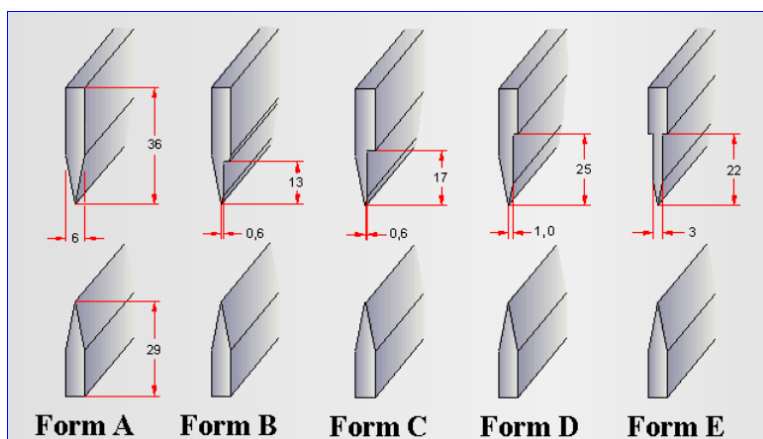

Designation of the tools:

1 set tool for the machine **NTE-200 L**
with the form "**E**"

= 1 set cutting tool **Wkzg200/E**

For boards with a thickness 1 mm
or smaller, add the suffix "**005**".

= 1 set cutting tool **Wkzg200/E/005**

Special shapes on request