

pcb - Depaneling Machine

NTE-200 P2

Data sheet

Werkzeuggestaltung Engl GmbH
Riegelweg 11
D-93164 Laaber
eMail: nte@pcb-depaneling.de

With the panel separator **NTE-200 P2**, pre-scored PCB panels can be separated gently and without bending stress for the circuit board and components. The cutting process takes place evenly and in parallel over the entire length. The tool opening can be continuously adjusted using a knurled screw. The drive is pneumatic.

Technical specifications:

Drive:	Pneumatic 6bar.
Separation.- length:	up to 200 mm.
Tool opening:-	adjustable up to 1.5 mm with knurled screw.
Weight:	approx. 55 kg.

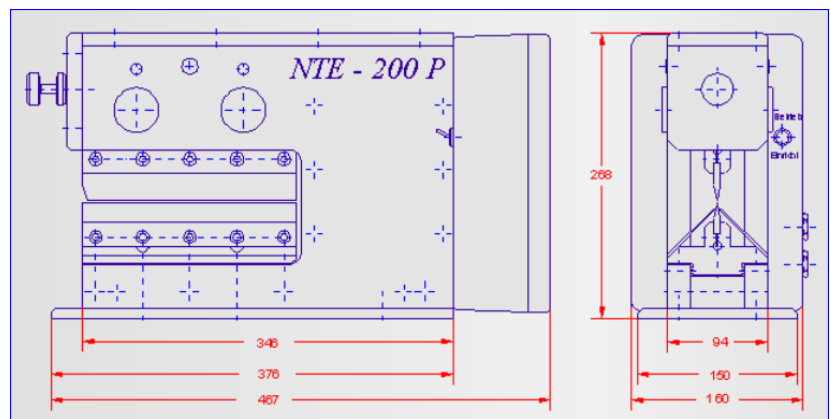

Scope of delivery

Table-top device including 2 sets of cutting tools, Form **A2**. Foot switch.

Tools forms A2.

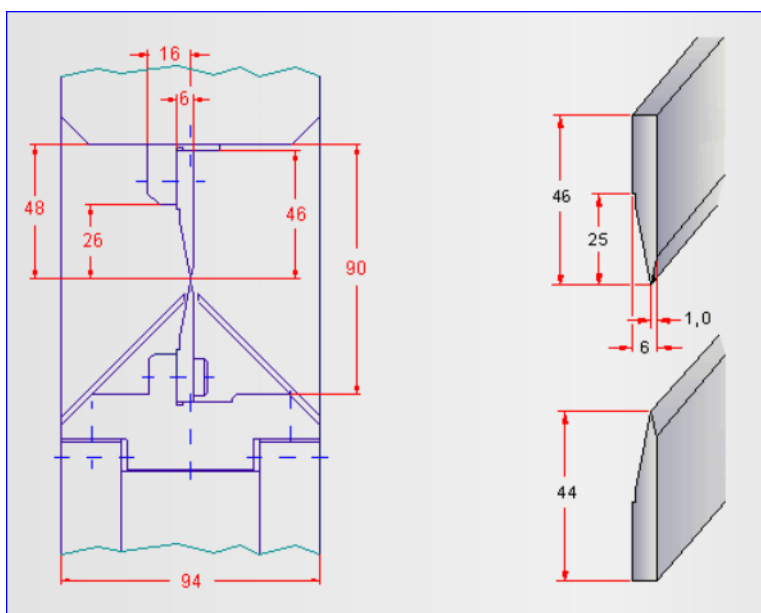

Designation of the tools:

1 set tool for the machine **NTE-200 P2**
with the form "**A2**"
= 1 set cutting tool **Wkzg200/A2**

For boards with a thickness 1 mm or
smaller, add the suffix "**005**".
= 1 set cutting tool **Wkzg200/A2/005**

Special shapes on request.