

pcb - Depaneling Machine

NTE-350 S2

Data sheet

Werkzeuggestaltung Engl GmbH
Riegelweg 11
D-93164 Laaber
eMail: nte@pcb-depaneling.de

With the panel separator **NTE-350 S2** pre-scored PCB panels can be separated gently and without bending stress for the circuit board and components. The cutting process takes place evenly and in parallel over the entire length. The electromechanical drive guarantees a constant cutting speed. The mold opening can be set quickly and reproducibly using a preset rotary switch. A change in the mold opening can be carried out precisely and in a matter of seconds..

Technical specifications:

| | |
|--------------------------|--|
| Drive | electromechanical 230 V / 50-60 Hz |
| Option: | 115 V / 50-60 Hz |
| Separation.-: length: | up to 300 mm. |
| Tool opening | 16 times reproducible from 0.4 to 1.5 mm. |
| Table top: | Leakage resistance 10 ⁶ bis 8x10 ⁶ Ohm with earthing system. |

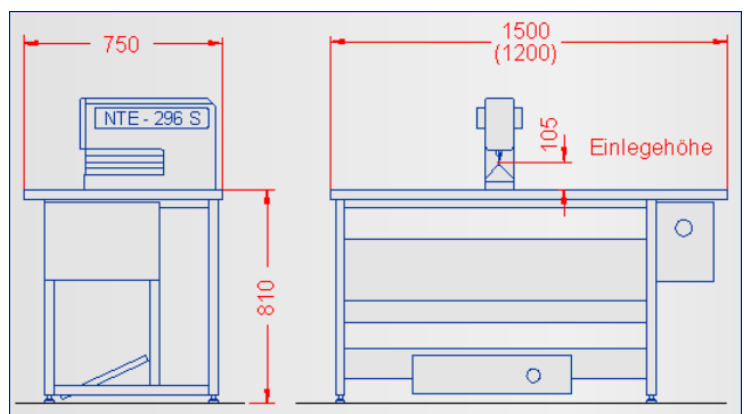

Weight: approx. 190 kg

Table frame: 1500 mm (option: 1200 mm) wide, 750 mm deep, 810 mm high.

Scope of delivery

The complete scope of the ready-to-connect machine includes: ESD-compliant table top, earthed footrest with integrated foot switch, a connection box for the earthing bracelet, as well as 2 sets of cutting tools, optionally Form A2.

Tools forms A2.

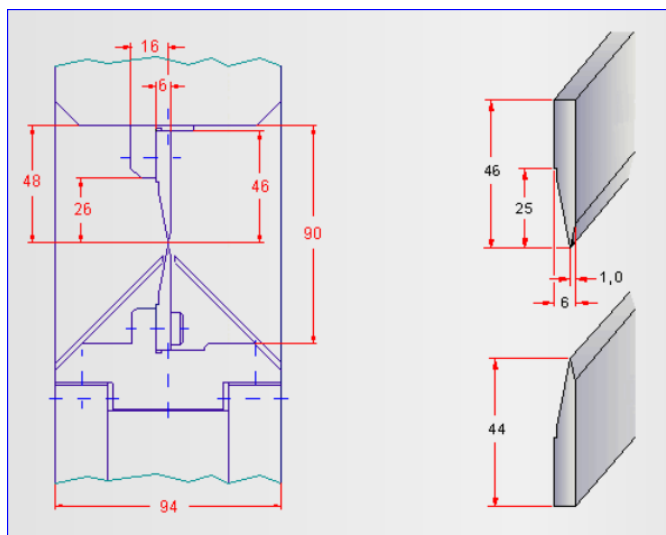

Designation of the tools:

1 set tool for the machine **NTE-350 S2**
with the form "**A2**"
= 1 set cutting tool **Wkzg350/A2**

For boards with a thickness 1 mm or
smaller, add the suffix "**005**".
= 1 set cutting tool **Wkzg350/A2/005**

Special shapes on request.