

Work-table for
NTE-296 S + 296 S2
NTE-350 S + 350 S2
Data sheet

Electrical control on the right outside. (standard)

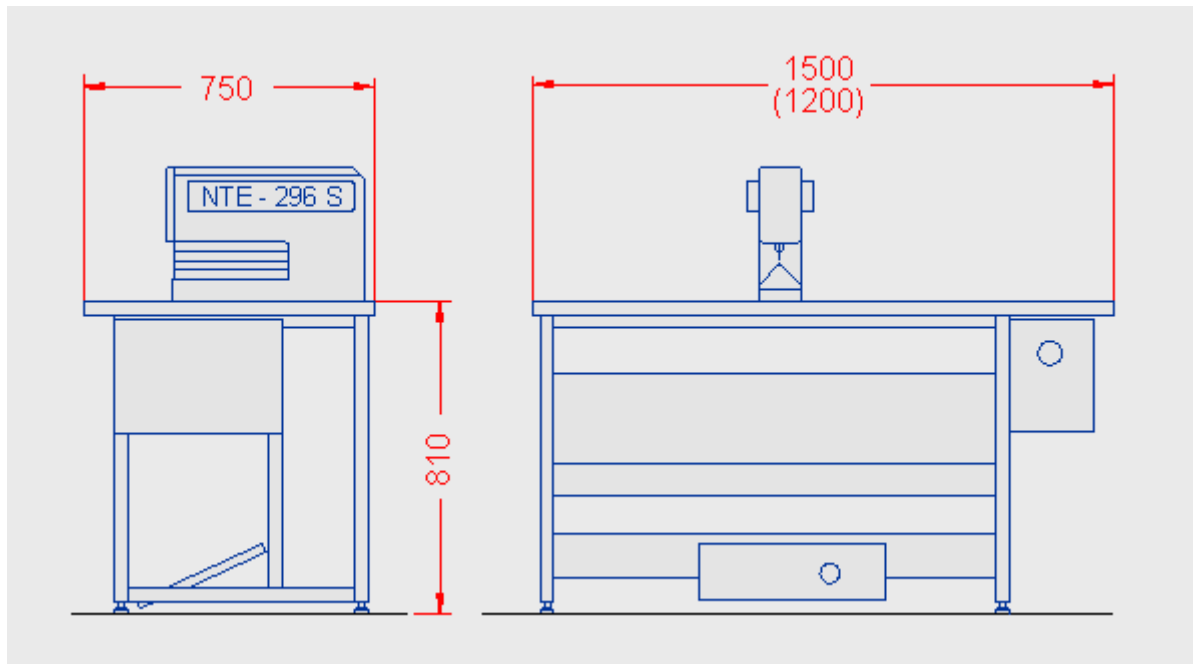

Electrical control on the right inside. (option)

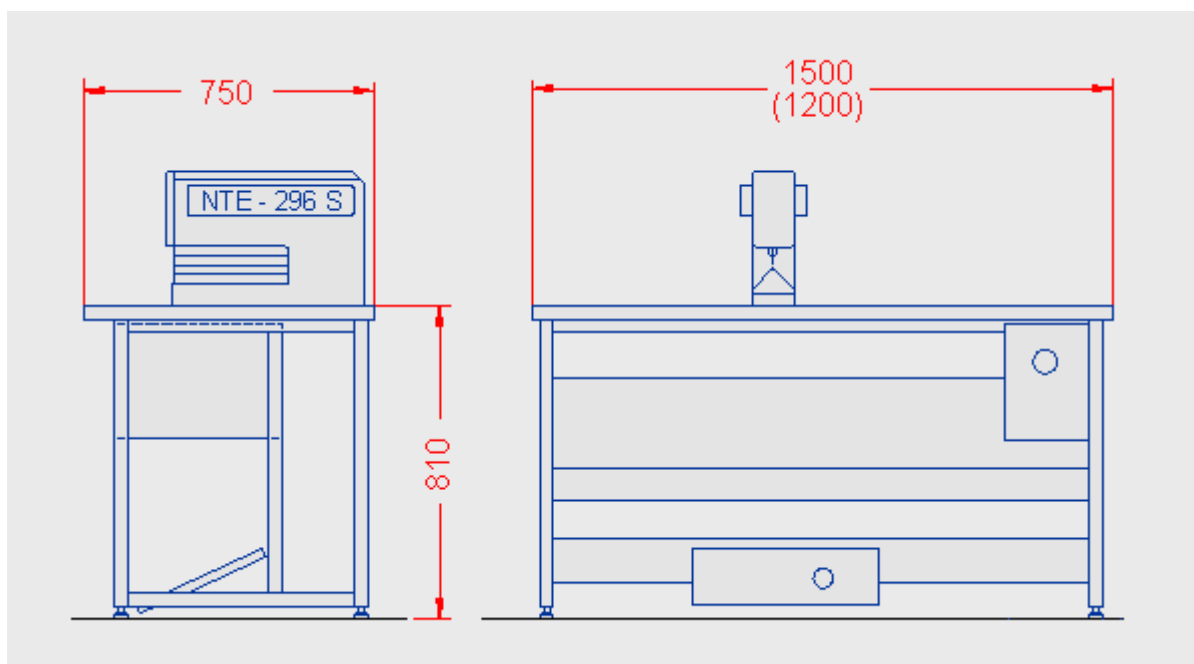

Work-table for
NTE-296 S + 296 S2
NTE-350 S + 350 S2
Data sheet

Electrical control on the left outside. (option)

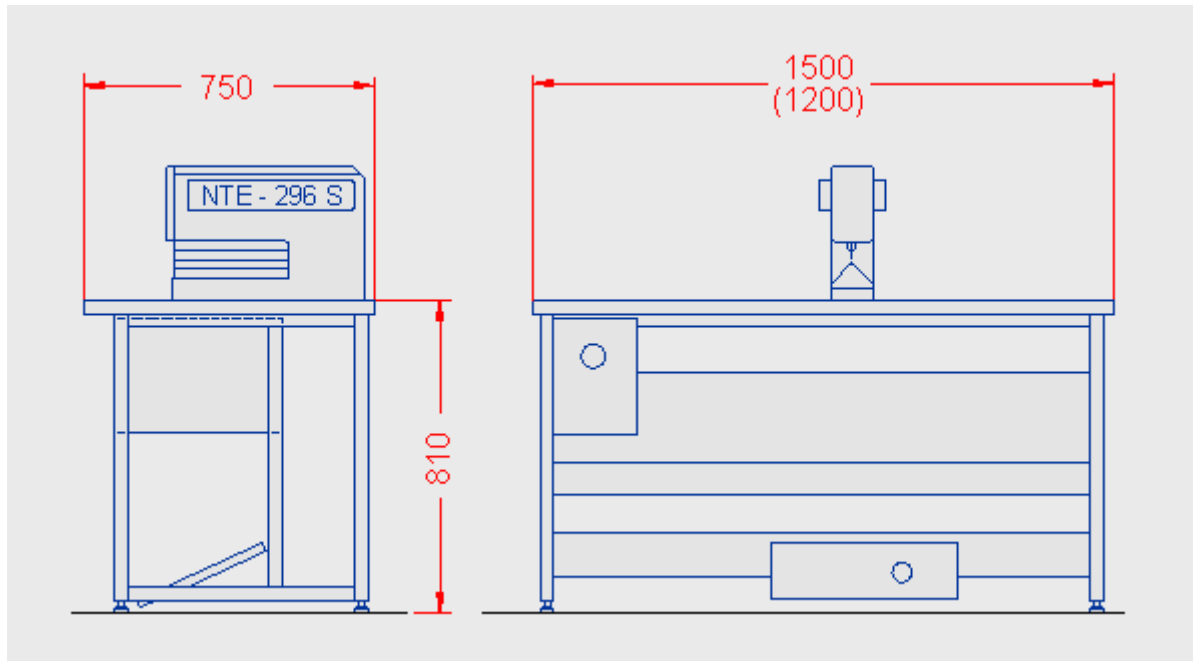

Electrical control on the left inside. (option)

